

**PIERCE COUNTY WISCONSIN**  
**DEPARTMENT OF LAND MANAGEMENT & RECORDS**  
Pierce County Courthouse  
414 W. Main Street P.O. BOX 647  
Ellsworth, Wisconsin 54011  
ZONING OFFICE 715-273-6747  
PLANNING OFFICE 715-273-6746  
Fax: 715-273-6864



**Private On-Site Wastewater Treatment System (POWTS)**  
**Holding Tank Component**

**General Submittal Information Check List:**

- State Sanitary Permit Application
- Sanitary Permit Fee - *Contact Pierce County Department of Land Management & Records at 715-273-6747.*
- Index & Title Sheet
- Plot Plan – *Must contain property location, municipality, and county information.*
- Holding Tank Cross Section & Specifications
- Manufacturers Tank Specifications
- Tank Anchoring Calculation
- Holding Tank User Manual
- Holding Tank Management Plan
- Holding Tank Servicing Contract
- Holding Tank Agreement – *Must have Town Chair's signature.*

**Private On-Site Wastewater Treatment System (POWTS)  
Index and Title Sheet**

Owner: \_\_\_\_\_

Project Name and System Type: \_\_\_\_\_

Location: \_\_\_\_\_

*Street Address*

*Legal Description*

*Township/County*

Holding Tank Component Manual (Check the one you are following):

Version 1 SBD-10571-P 6/11/1999 ...OR...

Version 2 SBD-10855-P 3/2007

Contents: Page 1: \_\_\_\_\_

Page 2: \_\_\_\_\_

Page 3: \_\_\_\_\_

Page 4: \_\_\_\_\_

Page 5: \_\_\_\_\_

Page 6: \_\_\_\_\_

Page 7: \_\_\_\_\_

Page 8: \_\_\_\_\_

Page 9: \_\_\_\_\_

Attachments: \_\_\_\_\_

\_\_\_\_\_

\_\_\_\_\_

Plumber/Designer: \_\_\_\_\_ Signed: \_\_\_\_\_

Credential Number: \_\_\_\_\_ Date: \_\_\_\_\_

Private On-Site Wastewater Treatment System (POWTS)  
**PLOT PLAN**

**FILE INFORMATION**

**PROPERTY LOCATION**

Owner	_____ ¼, _____ ¼, Section _____, T_____N, R_____E or W
PIN #	<input type="checkbox"/> City, <input type="checkbox"/> Village, <input type="checkbox"/> Town of  _____, Pierce County, WI



# Private On-Site Wastewater Treatment System (POWTS) HOLDING TANK CROSS SECTION & SPECIFICATIONS

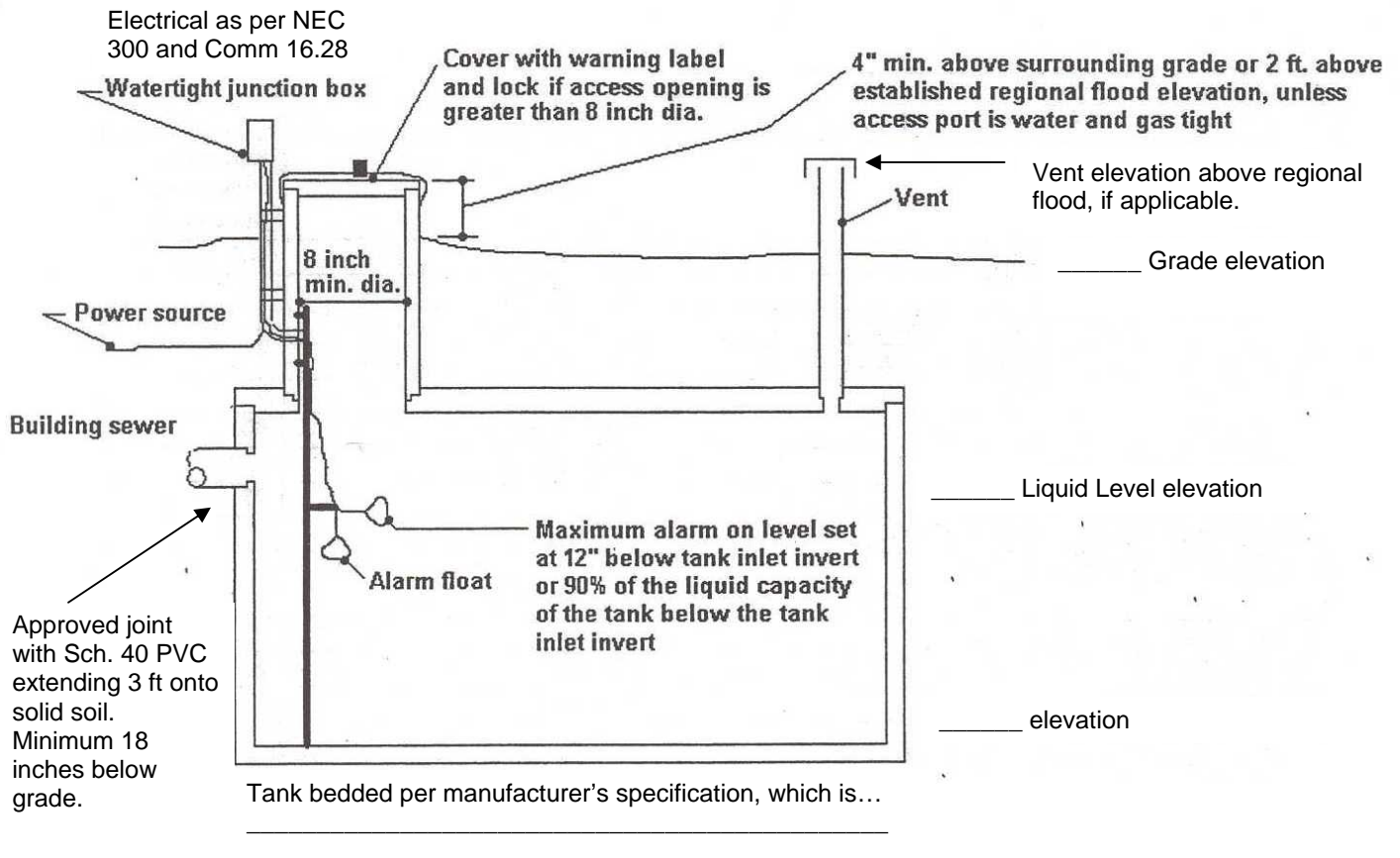

(If needed, insert different drawing to illustrate elevations, etc.)

Be sure to include manufacturer's drawing.

**Private On-Site Wastewater Treatment System (POWTS)**  
**TANK ANCHORING CALCULATION**

Per Comm 83.43(8)(g), Wis. Adm. Code, all tank(s) must be anchored whenever they are at risk for being installed in an area where they may be located in saturated conditions all/part of the year. Using soil as the anchor has become an acceptable alternative to concrete.

Flotation potential is the displacement of the tank calculated by its volume in cubic feet.

**Line A:** Calculate cubic feet of tank.

\_\_\_\_ inches high, x \_\_\_\_ inches wide, x \_\_\_\_ inches long, = \_\_\_\_ cubic inches.

Divide this number by 1728 to equal \_\_\_\_ cubic feet.

**Line B:** Convert the displacement to the weight of water.

\_\_\_\_ (from line A) cubic feet x 62.4 (weight of 1 cubic foot of water) x 1.5 (safety factor) =  
 \_\_\_\_ lbs. of lift potential.

**Line C:** Calculate weight needed to counter buoyancy.

\_\_\_\_ lbs. (Displacement weight from line B.) - \_\_\_\_ lbs. (weight of tank per manufacturer) = lbs. of soil needed to anchor tank: \_\_\_\_ lbs.

**Line D:** Weight of the soil media including safety factor needed over the tank to anchor the tank adequately.

Tank cover width \_\_\_\_ inches x tank cover length \_\_\_\_ inches, divided by 144 = \_\_\_\_ square feet x 0.083 (1 inch in foot decimal) = \_\_\_\_ cubic feet (volume of 1 inch of space over the tank cover).

**Line E:** Calculated weight of 1 inch of space over entire cover.

\_\_\_\_ cubic feet of space (from line D) x 100 lbs./cubic foot of = \_\_\_\_ lbs./inch\_space above cover .

**Line F:** Calculate inches of soil needed to counter buoyancy.

\_\_\_\_ lbs. (from line C) divided by \_\_\_\_ lbs. per inch of soil (from line E) = inches need over tank cover.

**Private On-Site Wastewater Treatment System (POWTS)  
HOLDING TANK SYSTEM - USER'S MANUAL**

**A. SYSTEM OPERATION:**

The holding tank system serves to contain wastewater on a site until the contents are pumped and hauled to a proper point of disposal by an individual certified under Wisconsin Administrative Code Chapter NR114.

Wastewater from your interior plumbing system enters the building sewer that terminates at the inlet of a prefabricated concrete holding tank system. The tank system has a switch that is set to activate when the liquid level reaches a point 12" below the tank inlet. The switch activates a high water alarm located inside a tank alert box that is installed on a pedestal or inside the dwelling. When the tank is full of wastewater, the switch will be activated and cause an audible alarm to sound. A switch located on the tank alert box can turn off the audible alarm. The liquid waste carrier contracted to service the holding tank system should be called immediately after the alarm is switched off. There is only a limited reserve capacity left in the holding tank system after the alarm has been activated.

**B. DESIGN FLOW:**

The holding tank system has a total wastewater capacity of \_\_\_\_\_ gallons. Servicing intervals cannot be predicted, as every household has varying water use habits. Use of water conserving fixtures and water conserving practices will increase the number of days before the tank needs to be serviced by a liquid waste carrier.

**C. WARNING:**

Failure to have the holding tanks serviced on a timely basis may cause wastewater to back up into the dwelling and/or discharge from the holding tank's manhole cover. The discharge of sewage to the surface of the ground is a public health hazard and subject to enforcement action by Pierce County.

Soil settling around the tank perimeter may occur after it has been backfilled. All depressions caused by soil settling should be filled with soil material to prevent surface water collection. Depressions left unfilled may allow surface water to freeze and cause frost damage to the manhole riser ring joints or the other tank components.

Do not drive over or near the buried holding tank system with any vehicle or construction equipment. This action may result in a cracked tank(s). This type of damage may allow groundwater to enter the holding tank(s) and increase the frequency of pumping.

Many disease-causing viruses, parasites, and bacteria are present in the holding tank's wastewater. Even the slightest exposure to wastewater may adversely affect one's health and increase the risk of serious illness.

**Please note that the owner of this POWTS must provide the septic servicing operator with reasonable access to the tank(s).** This may include (but is not limited to) construction of a designated drive or servicing pad to within 25 horizontal feet and/or to within 15 vertical feet to bottom of the tank(s), foot traffic over and through property, or vehicle traffic over and through property.

**D. TROUBLE-SHOOTING**

1. Wastewater backs-up or overflows manhole cover:
  - a. High water alarm not working.
  - b. Tanks not pumped.
2. High water alarm not working:
  - a. Tank alert box not plugged into electrical outlet.
  - b. Audible alarms switch on silent mode.
  - c. Tank switch installed improperly or defective.
  - d. Tank switch electrical connections faulty.
  - e. Electrical line to switch defective.
3. Groundwater entering tank:
  - a. Tank manhole riser ring joints leaking.
  - b. Tank sidewalls or base cracked.

**E. MAINTENANCE:**

1. The tank alert box has a test button that should be pushed once a month to assure the high water alarm system is working properly.
2. The float containing the high water alarm switch may need to be cleaned whenever scum or solids build up on its outer surface. Accumulation of solids on the float may interfere with switch activation.
3. All manhole covers padlocks should be oiled or greased periodically to ensure free movement of lock components.
4. The locking device should be inspected after each tank servicing to prevent unauthorized entry.

**F. CONTINGENCY PLAN IN THE EVENT OF FAILURE:**

A badly cracked holding tank may need to be replaced depending upon the amount of damage and the crack's location. The tank manufacturer should be contacted to make a determination as to whether the tank can be repaired or needs replacement. Groundwater may enter the cracked tank requiring more frequent servicing by the contracted liquid waste carrier until the tank is repaired or replaced.

**G. CONTACTS IN THE EVENT OF COMPONENT FAILURE**

REGULATORY AGENCY: Pierce County Department of Land Management  
414 W. Main Street, P.O. Box 647, Ellsworth, WI 54011  
(715) 273-6747

NAME OF INSTALLER: Name: \_\_\_\_\_  
Address: \_\_\_\_\_  
\_\_\_\_\_  
Phone: \_\_\_\_\_

TANK MANUFACTURER: Name: \_\_\_\_\_  
Address: \_\_\_\_\_  
\_\_\_\_\_  
Phone: \_\_\_\_\_

HIGH WATER ALARM SYSTEM MANUFACTURER: Name: \_\_\_\_\_  
Address: \_\_\_\_\_  
\_\_\_\_\_  
Phone: \_\_\_\_\_

**Private On-Site Wastewater Treatment System (POWTS)  
HOLDING TANK MANAGEMENT PLAN**

This Private Onsite Wastewater Treatment System (POWTS) has been designed, and is to be installed and maintained according to s. Comm 83, Wis. Admin. Code, the Holding Tank Component Manual (version 1 SBD-10571-P 6/11/1999 or version 2 SBD-10855-P 3/2007) Pierce County Sanitary Code.

1. This POWTS is designed to accommodate all wastewater generated by a \_\_\_\_\_ bedroom residence.
2. The owner of this POWTS is responsible for system operation and maintenance, including all provisions in the attached Holding Tank Servicing Contract and Maintenance Agreements.
3. Each time the wastewater in the tank reaches 90% of the tank(s) capacity or a level of 12" below the inlet (at which time the alarm will activate), the pumper listed in the current Servicing Contract must be called to empty the tank's contents and dispose of them in accordance with NR 113, Wis. Adm. Code.
4. At each service event, the service provider should visually inspect the condition of the tank, risers and manhole cover(s) and verify that the alarm system functions and manhole locking devices are present. Discrepancies are reported to the owner in a timely manner for corrective action. All corrective actions shall comply with the county sanitary ordinance and Comm 83 and 84 Wis. Adm. Code.
5. All service events or inspections of this POWTS shall be reported to the county in the semi-annual report.
6. The owner may not remove any of the wastes from the holding tank(s), or cause such wastes to be removed by any person not authorized to do so under Ch. 281, Wis. Statutes. The discharge of wastes tank to the ground surface, including intentional discharges and discharges caused by neglect, constitutes a failing POWTS and may result in issuance of correction orders or a citation by the county or state.
7. No one should enter a holding tank for any reason without being in full compliance with OSHA standards for entering a confined space. The atmosphere within these tanks may contain lethal gases, and rescue of a person from the interior of the tank may be difficult or impossible.
8. In the event that this POWTS fails and cannot be repaired, a code compliant replacement holding tank may be installed in the same location (a new sanitary permit is required for such a replacement). Connection to municipal services would also be considered at this time if they are deemed available to the property.
9. If this POWTS is replaced, or its use discontinued, components no longer in use it shall be abandoned in accordance with Comm 83.33 Wis. Adm. Code.
10. If there is a problem with, or question about this installation, the following persons should be contacted:
  - a. Installer: \_\_\_\_\_ Phone: \_\_\_\_\_
  - b. Service Provider: \_\_\_\_\_ Phone: \_\_\_\_\_
  - c. Regulatory Agency: Pierce County Department of Land Management Phone: (715) 273-6747

**Private On-Site Wastewater Treatment System (POWTS)  
HOLDING TANK SERVICING CONTRACT**

CONTRACT DATE

This contract is made between the

Holding Tank Owners(s) Name(s)	and	Pumper's Name
--------------------------------	-----	---------------

We acknowledge the installation of a holding tank(s) on the following property: (Provide legal descriptions:)

---



---



---

1. The owner agrees to file a copy of this contract with the local governmental unit that has signed the holding tank agreement required in s. COMM 83.54(3)(c), Wis. Adm. Code and Section VII of the Holding Tank Component Manual with the **Pierce County, Wisconsin.**
2. The owner agrees to have the holding tank(s) serviced by the Wisconsin Licensed Pumper and guarantees to permit the pumper to have access and to enter upon the property for the purpose of servicing the holding tank(s). The owner agrees to maintain the access road or drive so that the pumper can service the holding tank(s) with the pumping equipment. The owner further agrees to pay the pumper for all charges incurred in servicing the holding tank(s) as mutually agreed upon by the owner and pumper.
3. The pumper agrees to submit to the local governmental unit which has signed the pumping agreement required by s. Comm 83.55(1)(a), Wis. Adm. Code, and to the County, a report for the servicing of the holding tank(s) on a semiannual basis. The pumper further agrees to include the following in the semiannual report:
  - a. The name and address of the person responsible for servicing the holding tank;
  - b. The name of the owner of the holding tank;
  - c. The location of the property on which the holding tank is installed;
  - d. The sanitary permit number issued for the holding tank;
  - e. The dates on which the holding tank was serviced;
  - f. The volumes in gallons of the contents pumped from the holding tank for each servicing;
  - g. The disposal sites to which the contents from the holding tank were delivered.
4. This agreement will remain in effect until the owner or Wisconsin Licensed Pumper terminates this contract. In the event of a change in this contract, the owner agrees to file a copy of any changes to this service contract or a copy of a new service contract with the local governmental unit and the County named above within ten (10) business days from the date of change to this service contract.

Owner(s)Name(s) (Print)	Owner's Signature(s)	Subscribed and sworn to me on this date:
-----	-----	Today's Date:
Pumper's Name (Print)	Pumper's Signature	Notary Public Signature:
Pumper's Registration Number :	BL#                      Cert#	Commission Expiration:

**Drafted by** \_\_\_\_\_

# HOLDING TANK AGREEMENT

On this date \_\_\_\_\_, a holding tank agreement is made between the following:

County or Local Governmental Unit: \_\_\_\_\_

and the land owner(s)/holding tank owner(s): \_\_\_\_\_

We acknowledge the application is being made for the installation of a holding tank(s) on the following property: (Provided legal description below or  See Attached.)

Parcel Number: \_\_\_\_\_

Site Address: \_\_\_\_\_

Legal Description: \_\_\_\_\_

Document Number/Recording Area

Name and Return Address:

Pierce County Land Management Dept.  
County Courthouse, 414 W Main St,  
PO Box 647, Ellsworth, WI 54011

Or that continued use of the existing premises requires that a holding tank be installed on the property for the purpose of proper containment of sewage. Also, the property cannot now be served by a municipal sewer, or any other type of private sewage system as permitted under Ch. COMM 83, Wis. Adm. Code, Ch. 145 Statutes, and Ch. 191 Pierce County Sewage Disposal Code.

As an inducement to the County of Pierce to issue a sanitary permit for the above described property, we agree to do the following:

1. Owner agrees to conform to all applicable requirements of Ch. COMM 83, Wis. Adm. Code and Ch. 191 Pierce County Sewage Disposal Code relating to holding tanks. If the owner fails to have the holding tank properly serviced in response to orders issued by the County to prevent or abate a human health hazard as described in s. 254.59, Stats., the governmental unit may enter upon the property and service the tank or cause to have the tank to be serviced and charge the owner by placing the charges on the tax bill as a special assessment for current services rendered. The charges will be assessed as prescribed by s. 254.59 (2), Stats.
2. The owner agrees, pursuant to Section V. D. of the holding tank component manual, to have a water meter installed in all buildings or structures. Water meter shall be installed by a plumber authorized by the State of Wisconsin to conduct such installations, with said installation complying with State regulations and manufacturers specifications. The owner agrees to be finally responsible for the purchase, installation, maintenance, and repair of the water meter, and agrees to allow the governmental unit to enter the above described property on a regular basis to read and/or inspect the water meter.
3. Owner agrees to pay all charges and cost incurred by the governmental unit and/or County for inspection, pumping, hauling, or otherwise servicing and maintaining the holding tank in such a manner as to prevent or abate any human health hazard caused by the holding tank. The governmental unit shall notify the owner of any costs which shall be paid by the owner within thirty (30) days from the date of notice. In the event the owner does not pay the costs within thirty (30) days, the owner specifically agrees that all the costs and charges may be placed on the tax roll as a special assessment for the abatement of a human health hazard, and the tax shall be collected as provided by law.
4. The owner agrees to contract with a person who is licensed under Ch. NR 113, Wis. Adm. Code, to have the holding tank serviced.
5. The owner agrees to contract with a person licensed under Ch. NR 113, Wis. Adm. Code, who shall submit to the County a report in accordance with Chapter 191 General Code of Pierce County for the servicing of the holding tank. The County may enter upon the property to investigate the condition of the holding tank when pumping reports and meter readings may indicate that the holding tank is not being properly maintained.
6. This agreement will remain in effect only until the County certifies that the property is served by either a municipal sewer or a soil absorption system that complies with Ch. COMM 83, Wis. Adm. Code. In addition, this agreement may be canceled by executing and recording said certification with reference to this agreement in such manner which will permit the existence of the certification to be determined by reference to the property.
7. This agreement shall be binding upon the owner, the heirs of the owner, and assignees of the owner. The owner shall submit the agreement to the register of deeds, and the agreement shall be recorded by the register of deeds in a manner which will permit the existence of the agreement to be determined by reference to the property where the holding tank is installed.

Printed Owner(s) Name(s):

\_\_\_\_\_  
\_\_\_\_\_

Owner(s) Signature(s):

\_\_\_\_\_  
\_\_\_\_\_

Printed Government Official Name & Title:

\_\_\_\_\_  
\_\_\_\_\_

Government Official Signature:

\_\_\_\_\_  
\_\_\_\_\_

Witness hand & seal on this date:

\_\_\_\_\_  
\_\_\_\_\_

Notary Public Signature:

\_\_\_\_\_

Notary Public Printed Name:

\_\_\_\_\_

My commission expires:

\_\_\_\_\_

Drafted by: \_\_\_\_\_